

Walrus

© John Montroll

For Arctic Animals in Origami

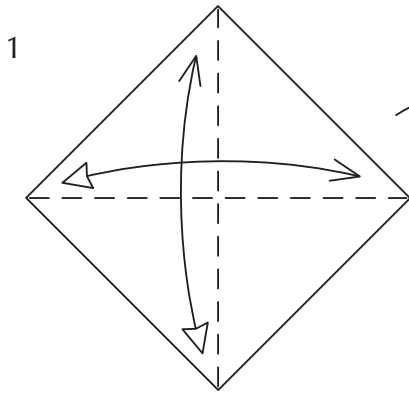
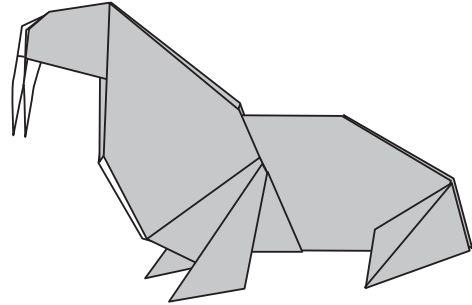

Fold and unfold.

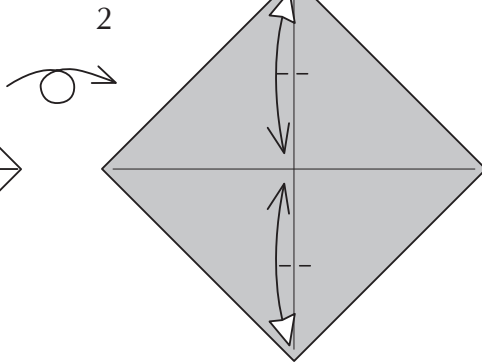

Fold and unfold.

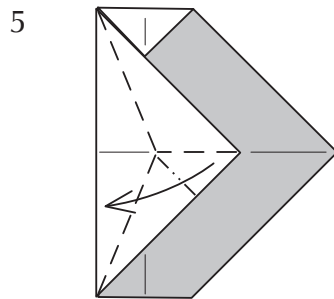
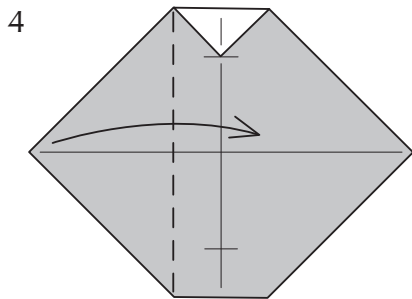
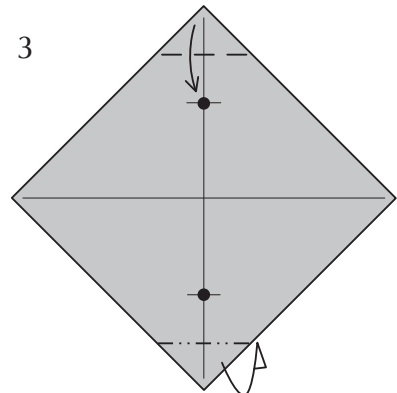

Rabbit-ear.

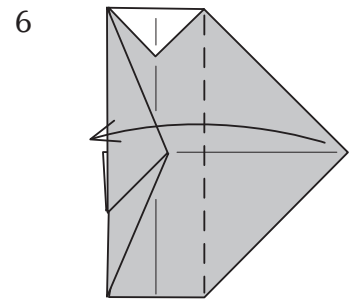

Repeat steps 4–5 on the right.

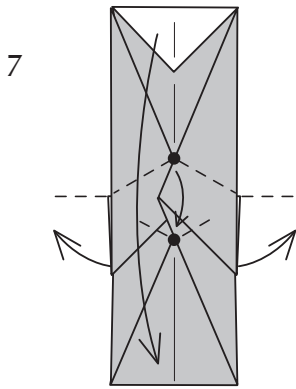

7
Spread the flaps on the left and right while folding in half. The dots will meet.

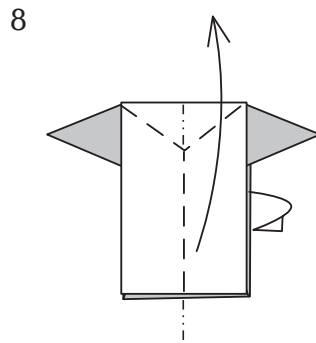

8
Lift the top layer up while folding in half. Rotate.

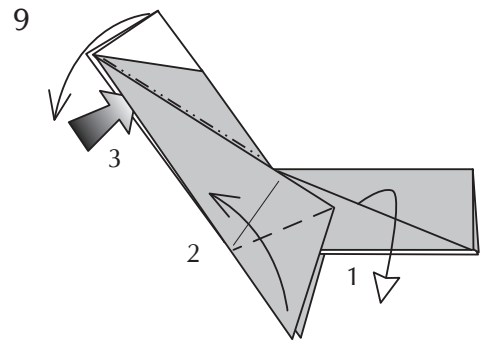

9
Fold 1 and 2 together, repeat behind. 3. Reverse-fold.

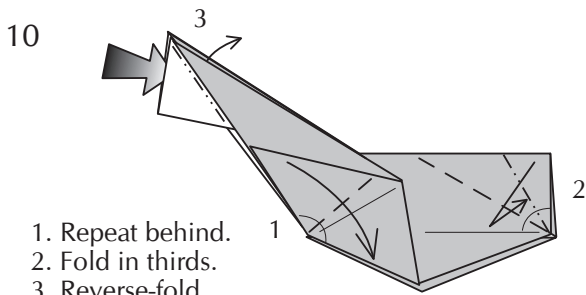

10
1. Repeat behind.
2. Fold in thirds.
3. Reverse-fold.

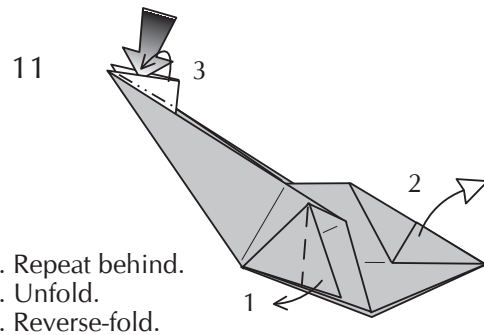

11
1. Repeat behind.
2. Unfold.
3. Reverse-fold.

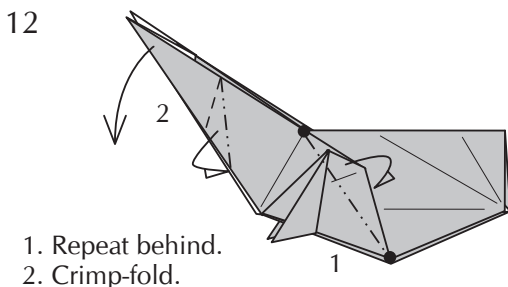

12
1. Repeat behind.
2. Crimp-fold.

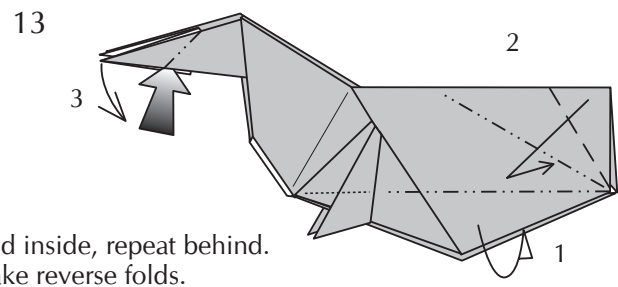

13
1. Fold inside, repeat behind.
2. Make reverse folds.
3. Reverse-fold, repeat behind.

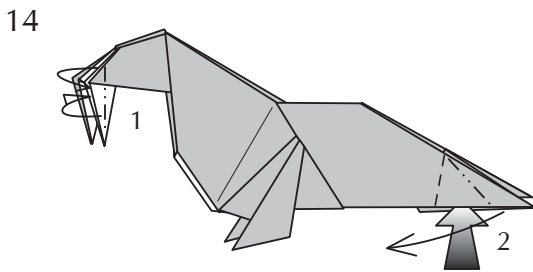

14
1. Thin the tusks on both sides.
2. Squash-fold.
Repeat behind.

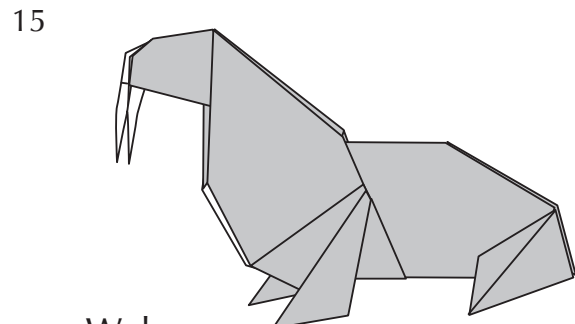

15
Walrus